

AIR-BOARD LIFT

Technical data

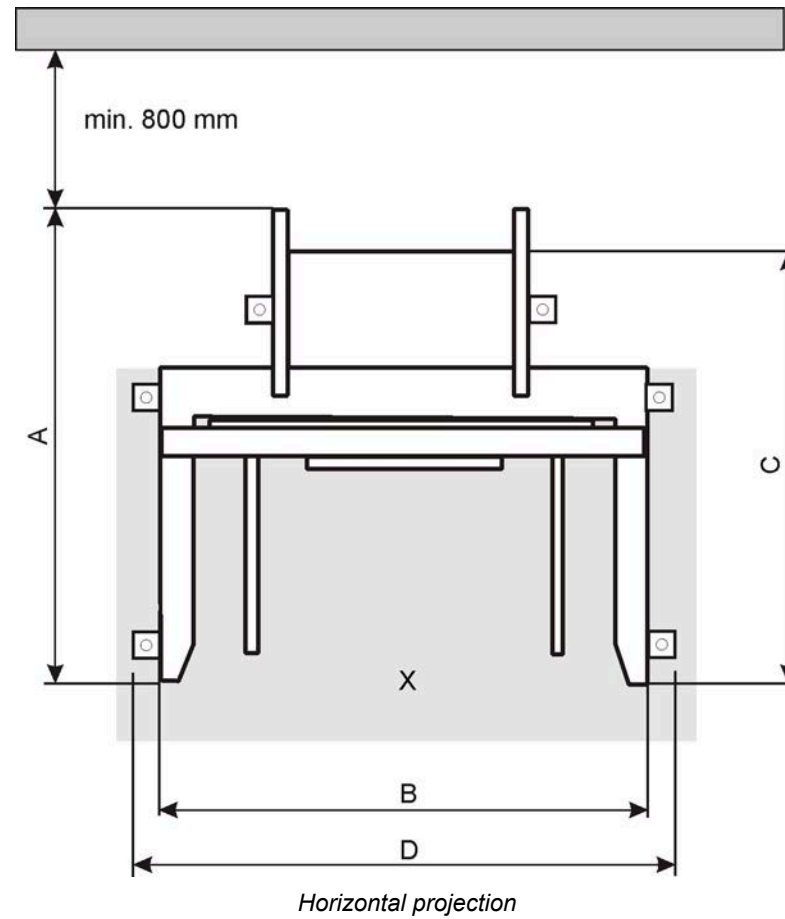

	LL - 600 - K - 3
A (mm)	1.710
B (mm)	1.380
C (mm)	1.545
D (mm)	1.615
Weight (kg)	680
Carrying capacity, max. (kg)	600
Size, max. (X x Y, mm)	1.110 X 905
Height of ream, min. (mm)	40
Size of air-boards (X x Y, mm)	990 x 1.150
Size of material pallet, max. (X x Y, mm)	1.040 x 990
Total height (mm)	1.780
Stroke from ... to table height, (mm)	50
Electrical power input (apparent power) (kVA)	1,4
Thermal rating (BTU/h)	4.541

The wire cross section of the main power supply according to the countrys regulations. Same regulations according the plug connectors.

Safety area

The safety area [X] below the liftforks and an additional area of 30 cm to the front has to be marked in black and yellow (not included in the scope of supply)!

Hydraulic data

Hydraulic working pressure: 150 bar!

Hydraulic unit is constructed for a maximum permissible pressure of 200 bar.